



CSW-200

High Traffic Commercial Swing Gate Operator

UL LISTINGS AND INSTRUCTIONS

INSTALLATION INSTRUCTIONS REGARDING THE GATE OPERATOR

- A) Install the gate operator only when:
- 1) The operator is appropriate for the construction and the usage Class of the gate.
 - 2) **All openings of a horizontal slide gate are guarded or screened from the bottom of the gate to a minimum of 4 feet (1.2 m) above the ground to prevent a 2 1/4inch (57.15 mm) diameter sphere from passing through the openings anywhere in the gate, and in that portion of the adjacent fence that the gate covers in the open position.**
 - 3) All exposed pinch points are eliminated or guarded, and
 - 4) Guarding is supplied for exposed rollers.
- B) The operator is intended for installation only on gates used for vehicles. Pedestrians must be supplied with a separate access opening.
- C) The gate must be installed in a location so that enough clearance is supplied between the gate and adjacent structures when opening and closing to reduce the risk of entrapment. Swinging gates shall not open into public access areas.
- D) The gate must be properly installed and work freely in both directions prior to the installation of the gate operator.
- E) -
- F) Controls must be far enough from the gate so that the user is prevented from coming in contact with the gate while operating the controls. Controls intended to be used to reset an operator after 2 sequential activations of the entrapment protection device or devices must be located in the line of sight of the gate outdoor or easily accessible controls shall have a security feature to prevent unauthorized use.
- G) All warning signs and placards must be installed where visible in the area of the gate.

UL LISTINGS AND INSTRUCTIONS

- H) For a gate operator utilizing a non-contact sensor such as a photo beam:
- 1) See instructions on the placement of non-contact sensor for each Type of application,
 - 2) Care shall be exercised to reduce the risk of nuisance tripping, such as when a vehicle trips the sensor while the gate still moving, and
 - 3) One or more non-contact sensors shall be located where the risk of entrapment or obstruction exists, such as the perimeter reachable by a moving gate or barrier.
- I) For a gate operator utilizing a contact sensor such as an edge sensor:
- 1) One or more contact sensors shall be located at the leading edge, trailing edge and postmounted both inside and outside of a vehicular horizontal slide gate.
 - 2) One or more contact sensors shall be located at the bottom edge of a vehicular vertical lift gate.
 - 3) One or more contact sensors shall be located at the pinch point of a vehicular vertical pivot gate.
 - 4) A hardwired contact sensor shall be located and its wiring arranged so that the communication between the sensor and the gate operator is not subjected to mechanical damage.
 - 5) A wireless contact sensor such as the one that transmits radio frequency (RF) signals to the gate operator for entrapment protection functions shall be located where the transmission of the signals are not obstructed or impeded by building structures, natural landscaping or similar obstruction. A wireless contact sensor shall function under the intended end-use conditions.

UL LISTINGS AND INSTRUCTIONS

IMPORTANT SAFETY INSTRUCTIONS

WARNING - To reduce the risk of injury or death:

1. READ AND FOLLOW ALL INSTRUCTIONS.
2. Never let children operate or play with gate controls. Keep the remote control away from children.
3. Always keep people and objects away from the gate while the gate is in operation. NO ONE SHOULD CROSS THE PATH OF A MOVING GATE.
4. Test the gate operator monthly. The gate MUST reverse on contact with a rigid object or stop when an object activates the non-contact sensors. After adjusting the force or the limit of travel, retest the gate operator, Failure to adjust and retest the gate operator properly can increase the risk of injury or death.
5. Use the emergency release only when the gate is not moving. Make sure the power for the gate operator is off.
6. KEEP GATES PROPERLY MAINTAINED. Read the manual. Have a qualified service person make repairs to the gate or gate hardware.
7. The entrance is for vehicles only. Pedestrians must use separate entrance.
8. SAVE THESE INSTRUCTIONS.

UL LISTINGS AND INSTRUCTIONS

Gate – A moving barrier such as a swinging, sliding, raising lowering, rolling, or like, barrier, that is a stand-alone passage barrier or is that portion of a wall or fence system that controls entrance and/or egress by persons or vehicles and completes the perimeter of a defined area.

Vehicular horizontal slide-gate operator (or system) – A vehicular gate operator (or system) that controls a gate which slides in a horizontal direction that is intended for use for vehicular entrance or exit to a drive, parking lot, or the like.



Residential vehicular gate operator – Class I – A vehicular gate operator (or system) intended for use in a home of one-to four single family dwelling, or a garage or parking area associated therewith.

Commercial/General access vehicular gate operator – Class II – A vehicular gate operator (or system) intended for use in a commercial location or building such as a multi-family housing unit (five or more single family units) hotel, garages, retail store or other building servicing the general public.

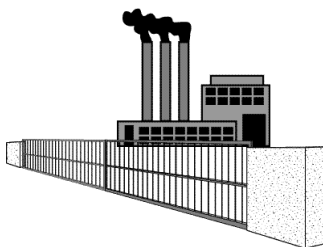
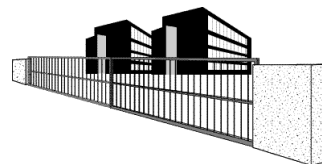

Commercial/General access vehicular gate operator – Class III – A vehicular gate operator (or system) intended for use in a industrial location or building such as a factory or loading dock area or other locations not intended to service the general public.

Restricted access vehicular gate operator – Class IV – A vehicular gate operator (or system) intended for use in a guarded industrial location or building such as an airport security area or other restricted access locations not servicing the general public, in which unauthorized access is prevented via supervision by security personnel.

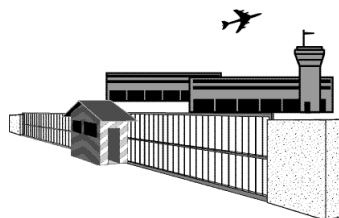

CONCRETE PAD AND GATE ATTACHMENT

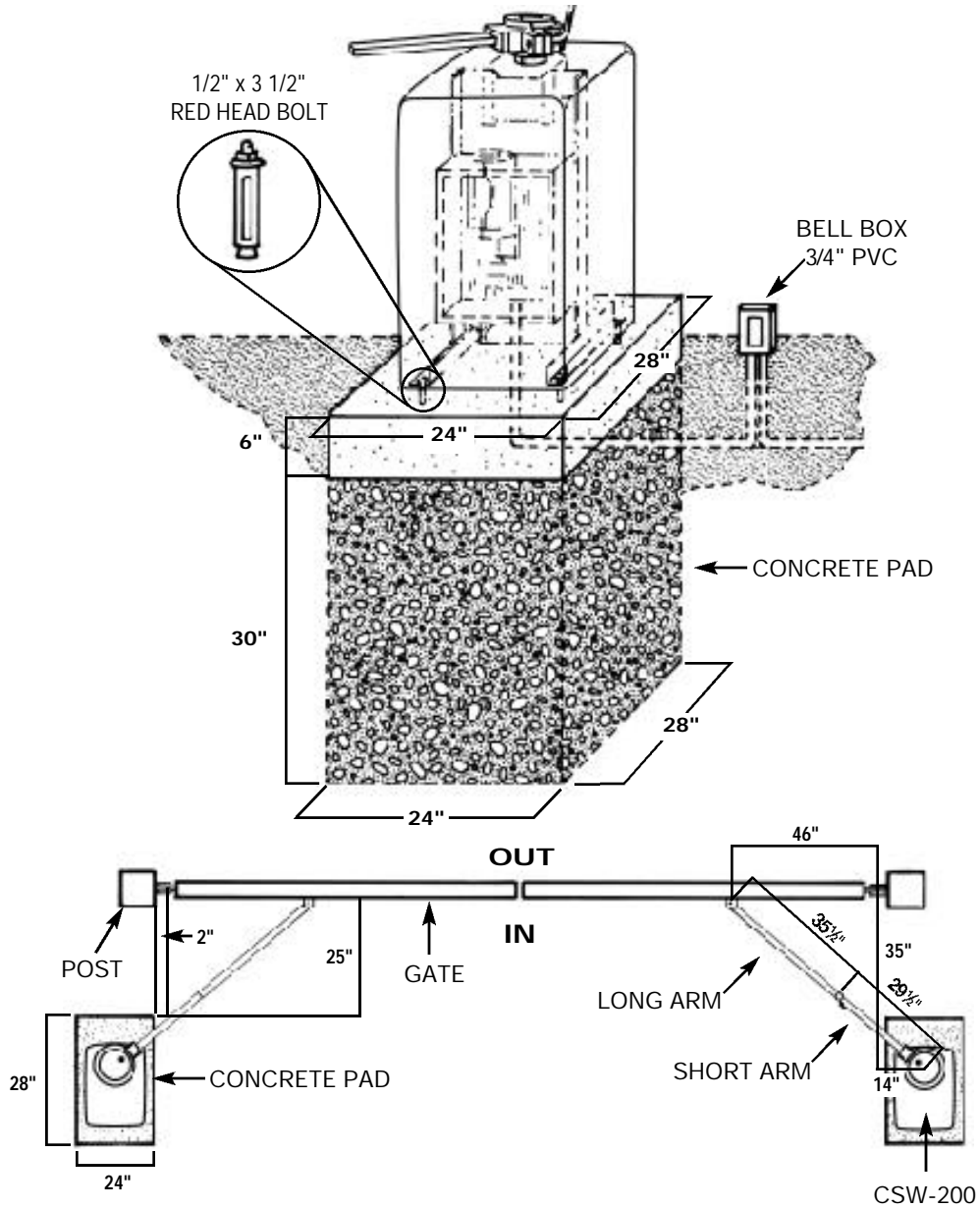

COMPACT INSTALLATION

COMPACT INSTALLATION ONLY:
DO NOT USE THESE MEASUREMENTS FOR A STANDARD INSTALLATION.
THIS IS ONLY FOR A COMPACT INSTALLATION

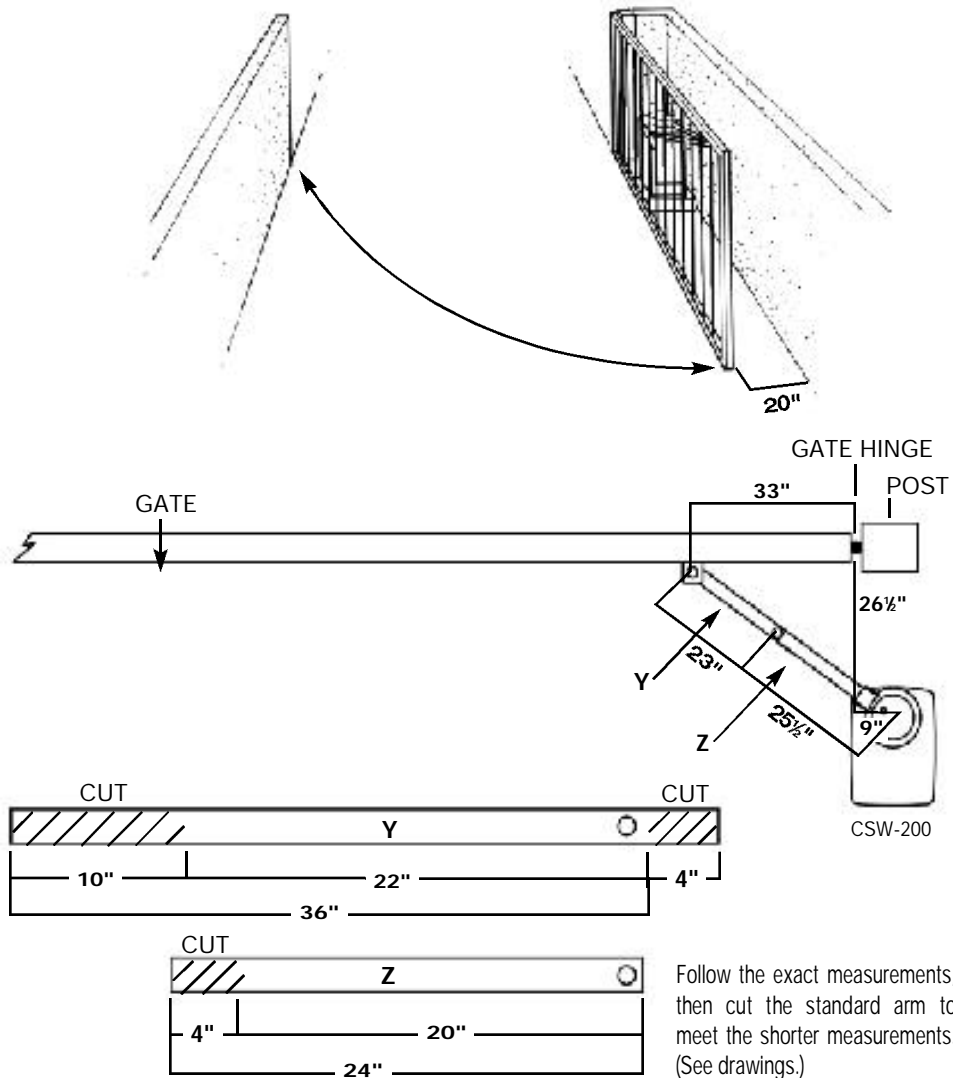

REGULAR INSTALLATION

STANDARD INSTALLATION IS SHOWN ON PAGE 6

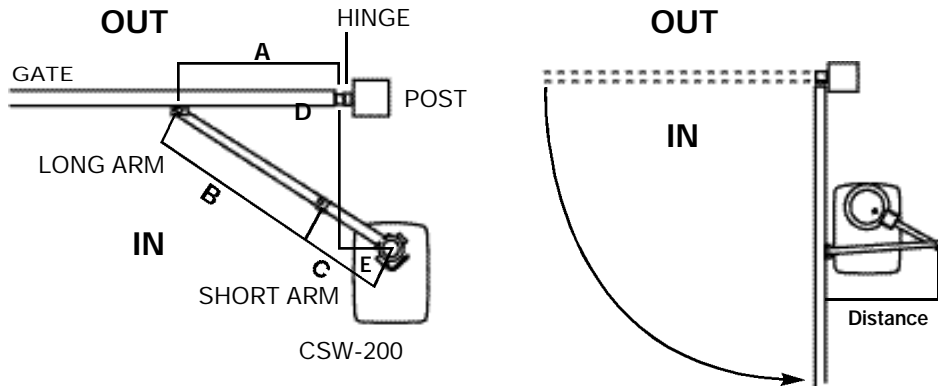

Distances (A) thru (E) are from the center of one pivot point to the center of another pivot point.

SUGGESTION: If the gate is longer than 18 feet, follow chart A: A-2.

CAUTION: The distance between the gate and the concrete bed is always 10 inches less than distance D.

EXAMPLE: D = 42", if the distance between the gate and concrete bed is 32".

CHART A

	A	B	C	D	E	Distance
1	46"	35½"	29½"	35"	11"	45"
2	46¾"	35½"	33½"	42"	11"	37"
3	46¾"	35½"	31½"	40"	11"	41"
4	47¼"	37¼"	30"	37"	11"	45"
5	47"	35"	29½"	32"	11"	45"
6	42½"	33"	26½"	28½"	11"	41"

CHART B

	A	B	C	D	E	Distance
1	34½"	35¾"	29½"	35"	14"	43"
2	44"	36½"	32½"	42"	14"	32"
3	44"	37"	30½"	40"	14"	40"
4	45"	37"	30½"	37"	14"	43"
5	44¾"	35¾"	29½"	32"	14"	44"
6	41"	39"	27½"	28½"	14"	41"

GATE ARM INSTALLATION

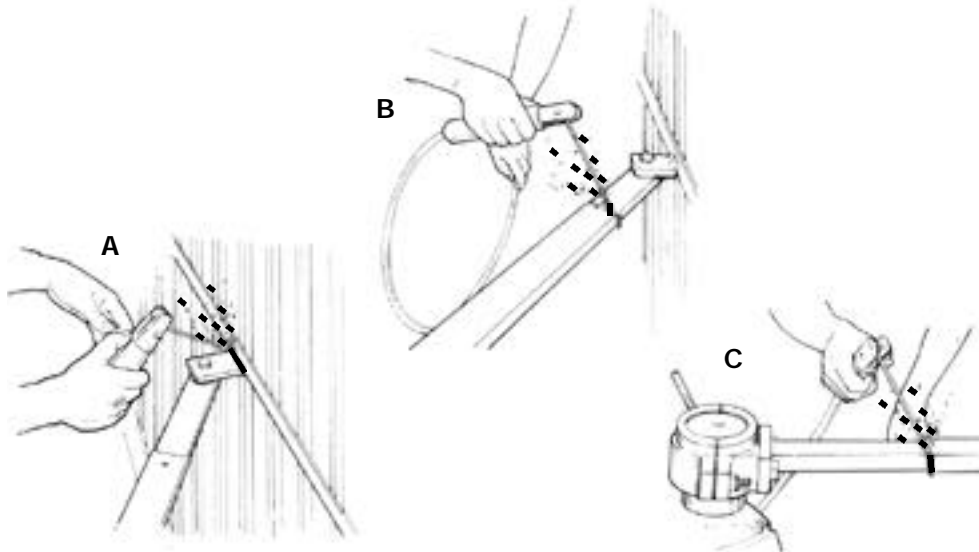
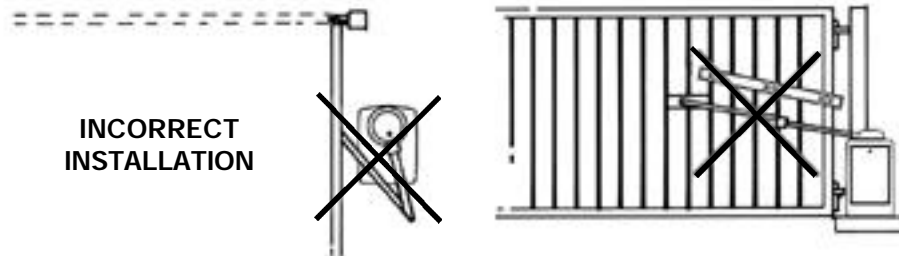

Once the gate arm measurements are calculated, weld the bracket on the gate. Weld the longer arm first, then weld the shorter arm. Make sure around the tube is welded completely.

ADJUSTMENT OF OUTPUT SHAFT

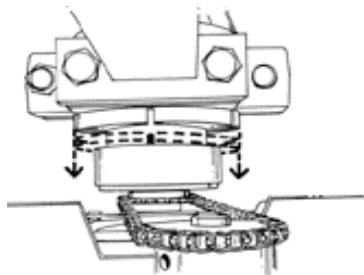

1. Make sure the pin fits in the notch as shown above.

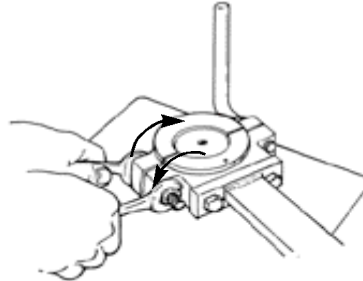

2. Place the red handle in 90° position. By tightening the nut you will be able to adjust the clutch.

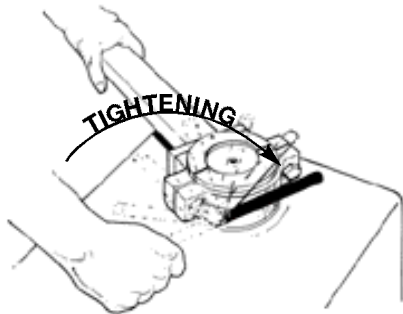

3. Place the red handle back in its original position.

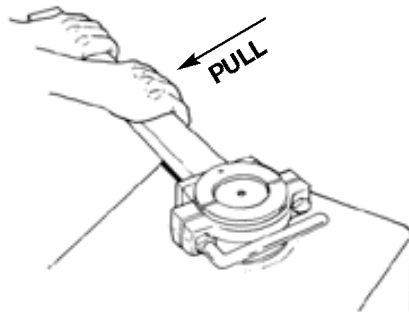

4. Pull the short arm away from the gate. Make sure slipping does not occur, if it does, then repeat step no. 2 & 3.

ADJUSTING GATE TRAVELING DISTANCE

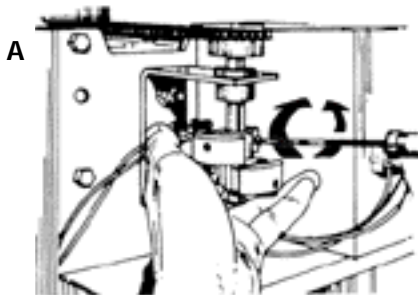

A. Release the red handle and open the gate to a distance desired. Loosen the bolt (as shown in picture "A"). Turn plastic part until the half moon shape hits the limit switch. For closing cycle, do the same.

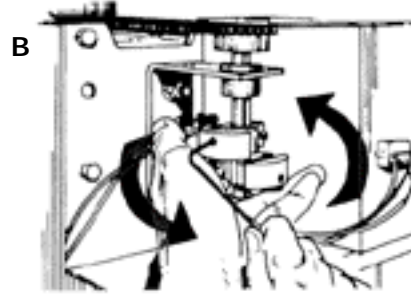

B. For a more precise adjustment, you may use the set screw (picture "B").

CHOOSING MOVEMENT DIRECTION

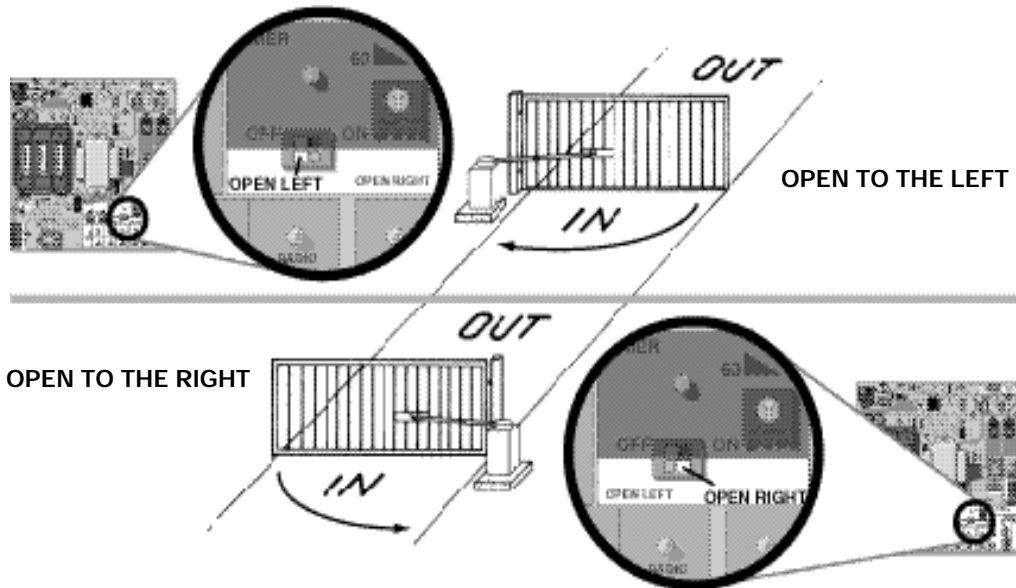

HOW TO CONNECT POWER (120V)

BLACK = 115 VAC
WHITE = NEUTRAL
GREEN = GROUND

SUGGESTION: Once you are through wiring hook-ups, you may want to seal all open holes with silicon or another substance.

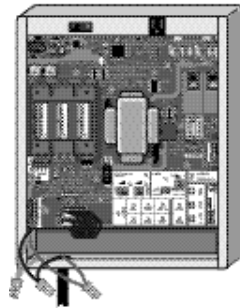

USE (U.L. LISTED) CONDUIT FOR SUPPLYING POWER TO THE UNIT

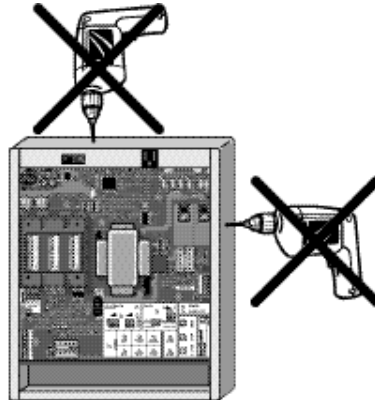

WIRE GAUGE REQUIREMENT FOR 115VAC POWER SUPPLY: 1/2 HP & DUAL MOTOR ONLY

16 GAUGE	14 GAUGE	12 GAUGE	10 GAUGE	8 GAUGE	4 GAUGE
150 FEET	250 FEET	400 FEET	650 FEET	1000 FEET	2200 FEET

CAUTION: ELITE ACCESS SYSTEMS, INC. IS NOT RESPONSIBLE FOR CONFLICTS BETWEEN THE INFORMATION LISTED IN THE ABOVE CHART AND THE REQUIREMENTS OF YOUR LOCAL BUILDING CODES. THE INFORMATION IS FOR SUGGESTED USE ONLY. CHECK YOUR LOCAL CODES BEFORE INSTALLATION.

CLUTCH ADJUSTMENT

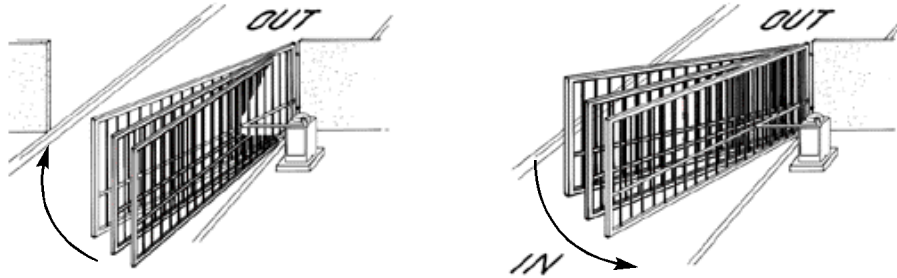

The adjustment is for a gate that is over 300 pounds and 12 feet long or longer. While the gate is closing, instantly an "open" command is given as shown above; the clutch may slip a bit, max. of 1/4 to 3/4 of a turn (slippage depends on the weight of the gate). If it does not slip, then readjust the clutch.

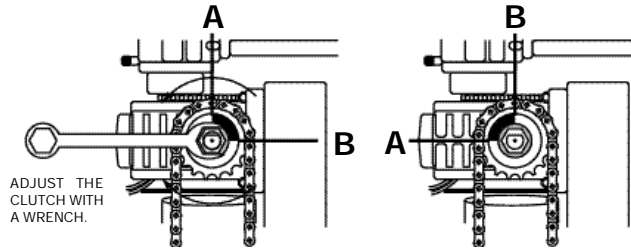

IMPORTANT!

Installers are required to adhere to this procedure: The UL required Warning Signs must be installed in plain view and on **both sides** of each commercial gate installed. Each sign is made with fastening holes in each corner and should be permanently secured in a suitable manner. Also the warning sticker should be placed on the operator so it is clearly visible.



TWO-WAY ADJUSTABLE REVERSING SENSOR

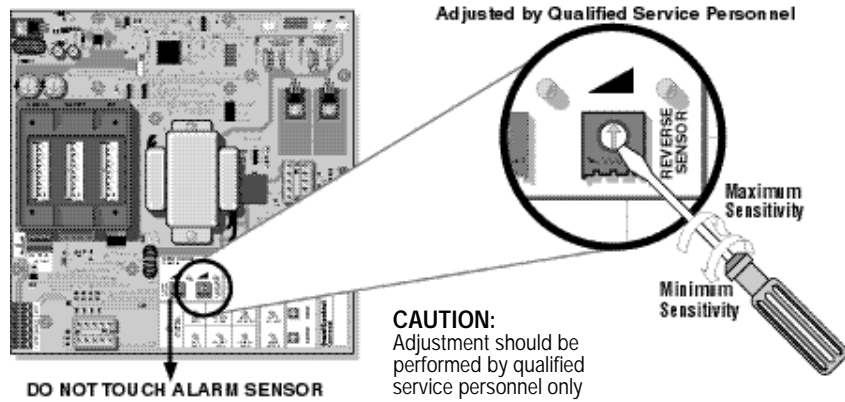

The level of sensitivity has to do with the weight of the gate and the condition of installation.
Too sensitive = if the gate stops or reverses by itself.
Not sensitive enough = if the gate hits an object and does not stop or reverse.

CAUTION: If the power supply to the gate operator is less than 99 volts, adjust the alarm by turning the alarm adjustment clockwise enough to actuate the alarm when obstructed but not sensitive enough for false triggering to occur.

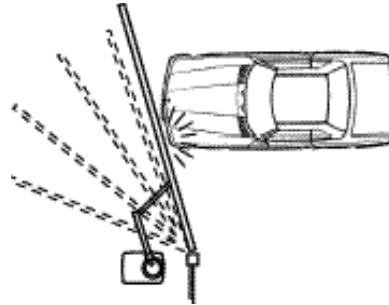

ADJUSTABLE TIMER

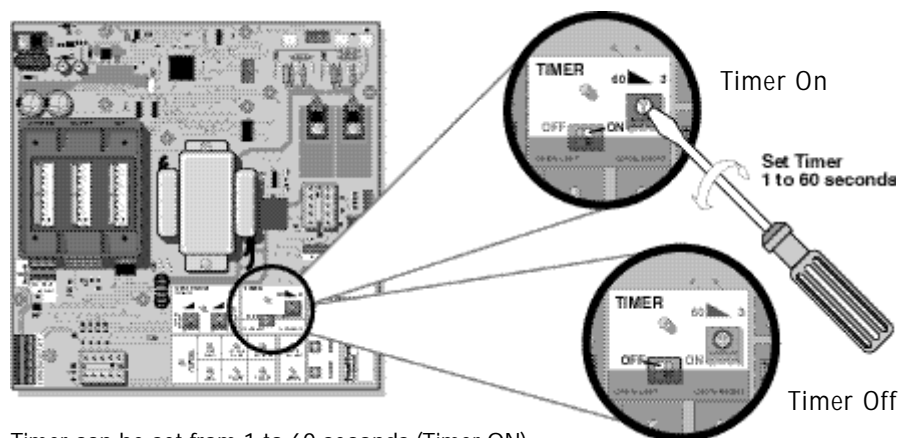

Timer can be set from 1 to 60 seconds (Timer ON),
or for push open/push close type operation (Timer OFF).

MASTER AND SLAVE WITH TIMER ON

Master board
Primary control
for system

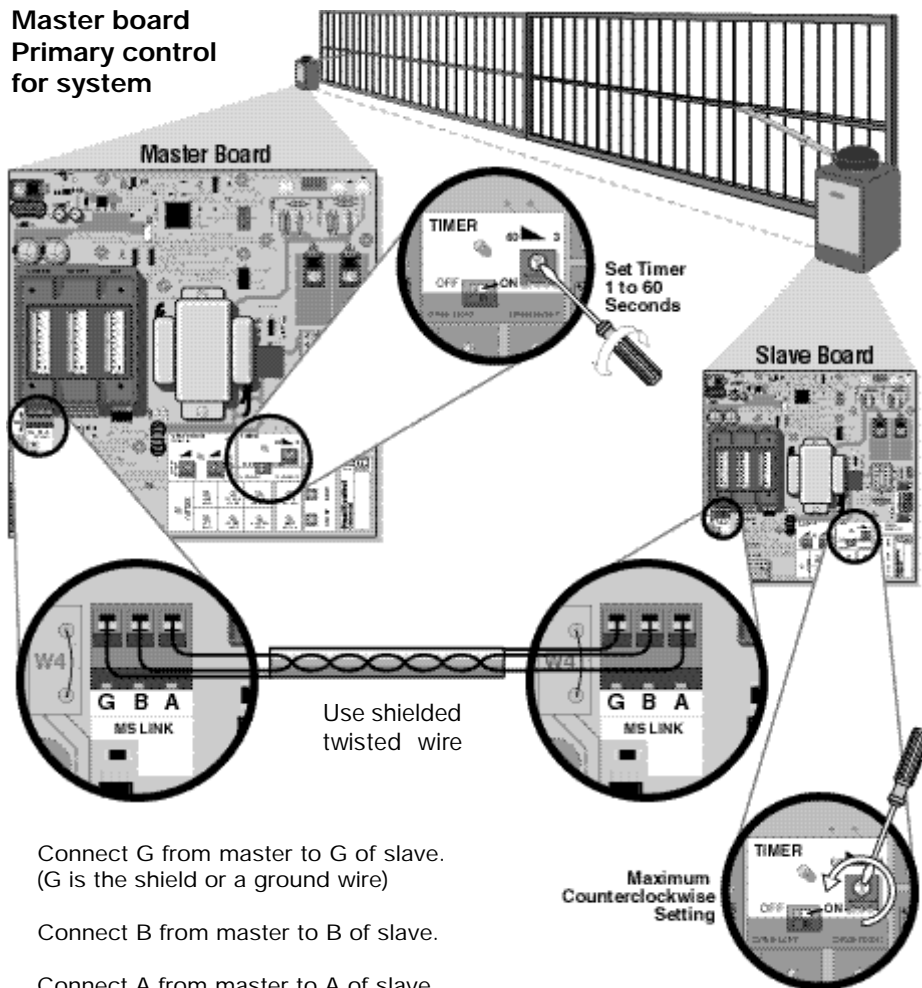

Connect G from master to G of slave.
(G is the shield or a ground wire)

Connect B from master to B of slave.

Connect A from master to A of slave.
Set Master Timer pot only to desired
time.

Set Slave Timer pot to maximum
counterclockwise setting.

Master timer must be on.

**Master and
Slave boards are
interchangeable**

MASTER AND SLAVE WITH TIMER OFF

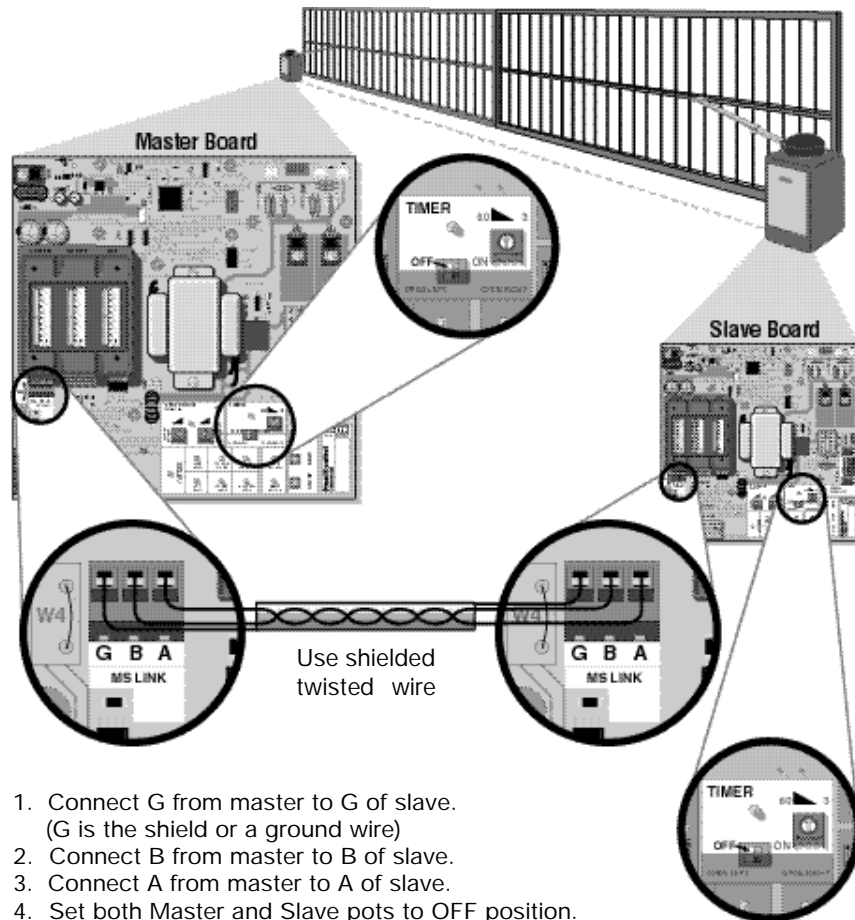

PARTIAL MASTER/INDIVIDUAL CONTROL

IN ORDER FOR THE FOLLOWING OPERATION TO OCCUR, FOLLOW THE INSTRUCTIONS.

EXAMPLE: There is a double gate, the entry gate is to be opened with a radio transmitter and the exit gate with a free exit loop. Only one safety loop system is to open both gates, and a fire department switch should open both gates at the same time.

1. Connect the radio receiver to entry gate only.
2. Connect the exit loop to exit gate only.
3. Connect the safety loop to both entry and exit gates.
4. Connect the fire department switch to both entry and exit gates.

INSTRUCTIONS FOR OPTIONAL SYSTEMS

Optional Omni board
Model # O-OMNI EXB

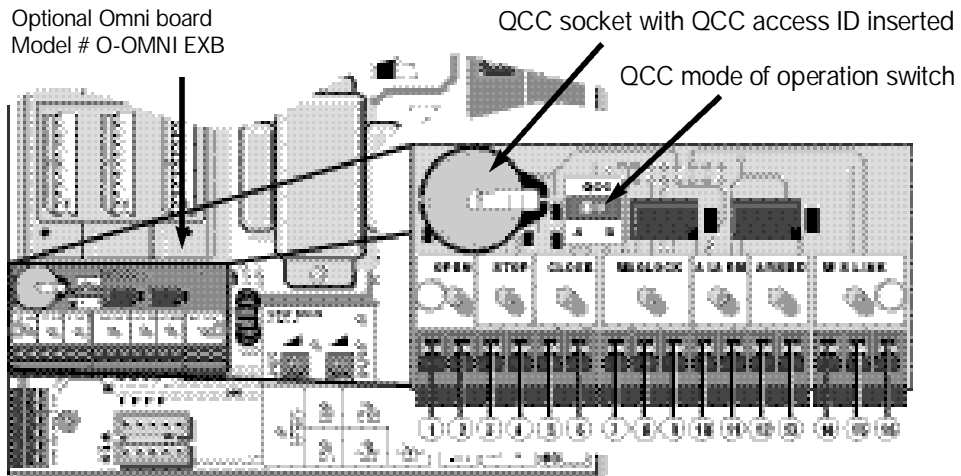

QCC IS DESIGNED FOR SLIDE GATE OPERATORS ONLY!

- | | |
|-----------------------|--------------------------------|
| 1 & 2 - Open Command | 10 & 11 - Burglar Alarm Output |
| 3 & 4 - Stop Command | 12 & 13 - Burglar Alarm Input |
| 5 & 6 - Close Command | 14 - Ground |
| 7 - Common | 15 - B |
| 8 - Normally Closed | 16 - A |
| 9 - Normally Open | |
- Maglock or Solenoid Master/Slave RS485

MASTER/SLAVE WITH OPTIONAL BOARD

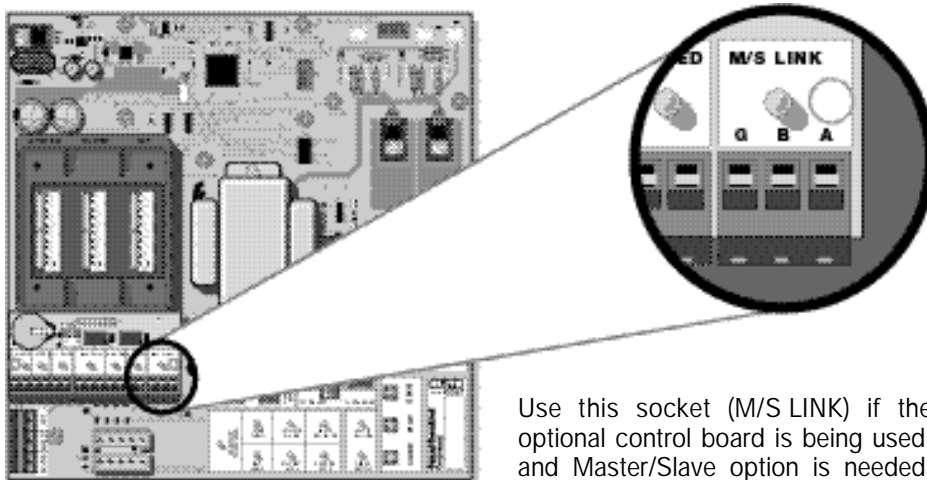

SOLENOID CONNECTION WITH OPTIONAL BOARD

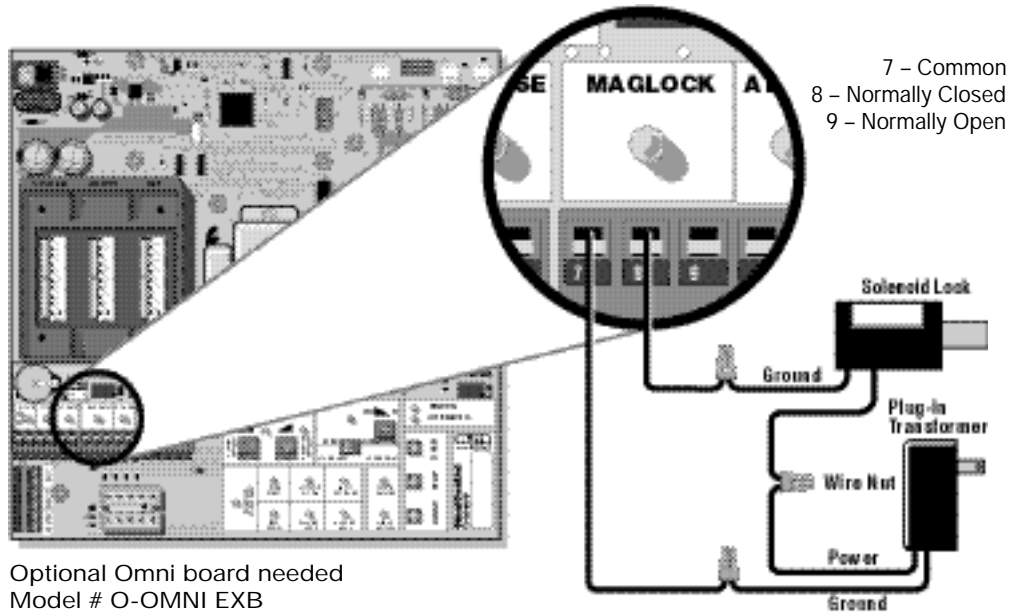

MAGLOCK CONNECTION WITH OPTIONAL BOARD

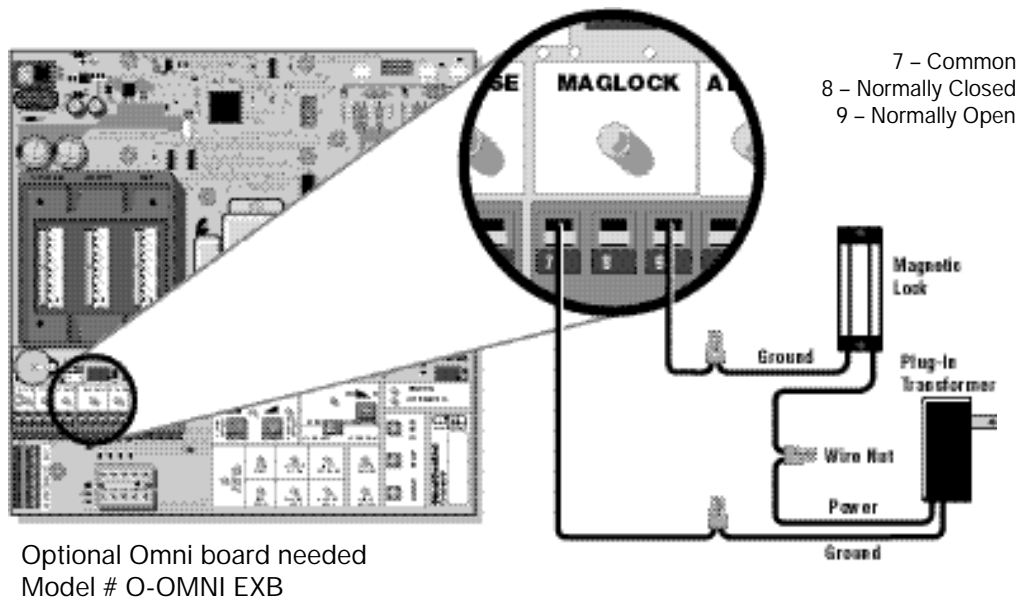

SOLENOID/MAGLOCK J3 CONNECTION

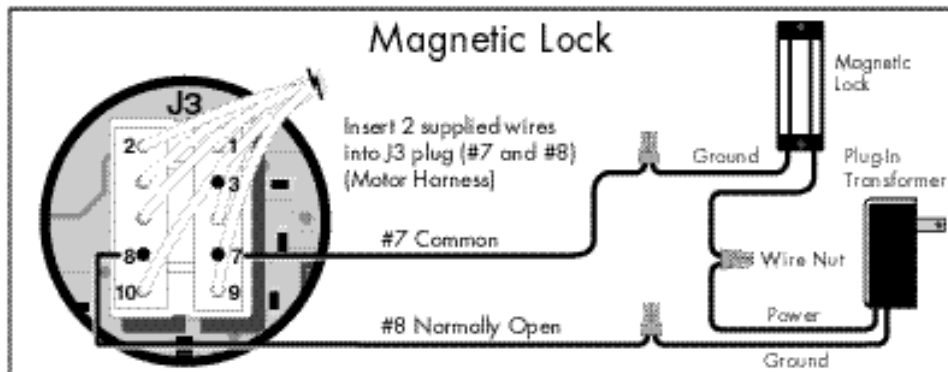
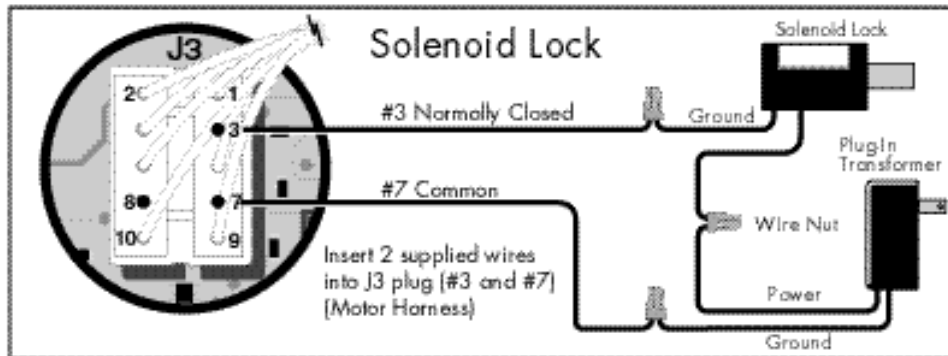
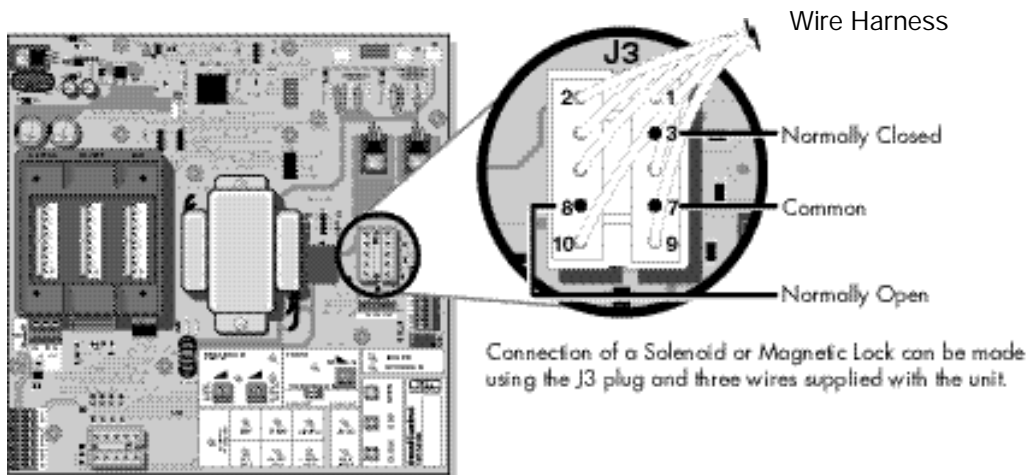

HOUSE ALARM/PROXIMITY SWITCH CONNECTIONS

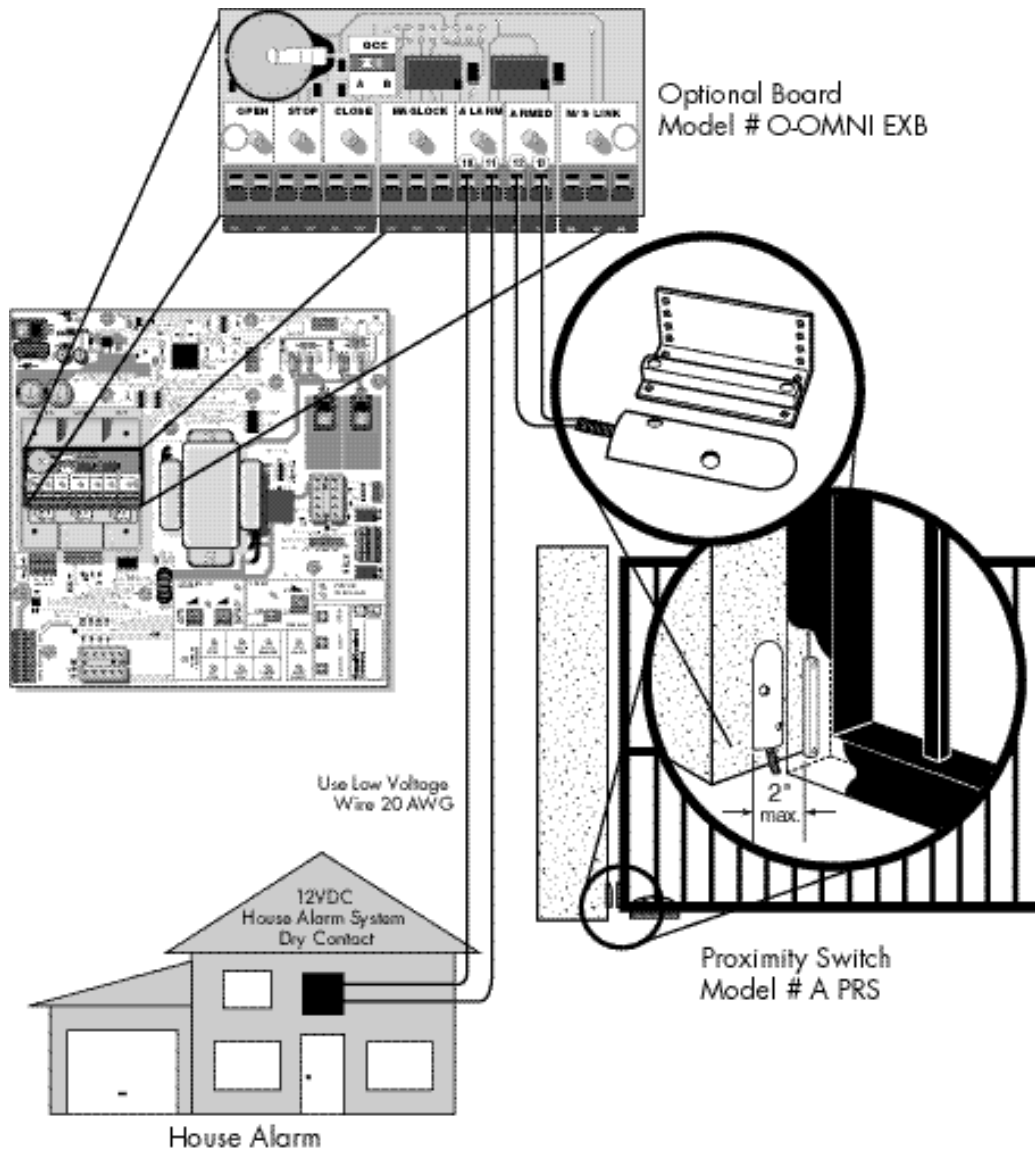

OPTIONAL BUILT-IN LOOP DETECTORS

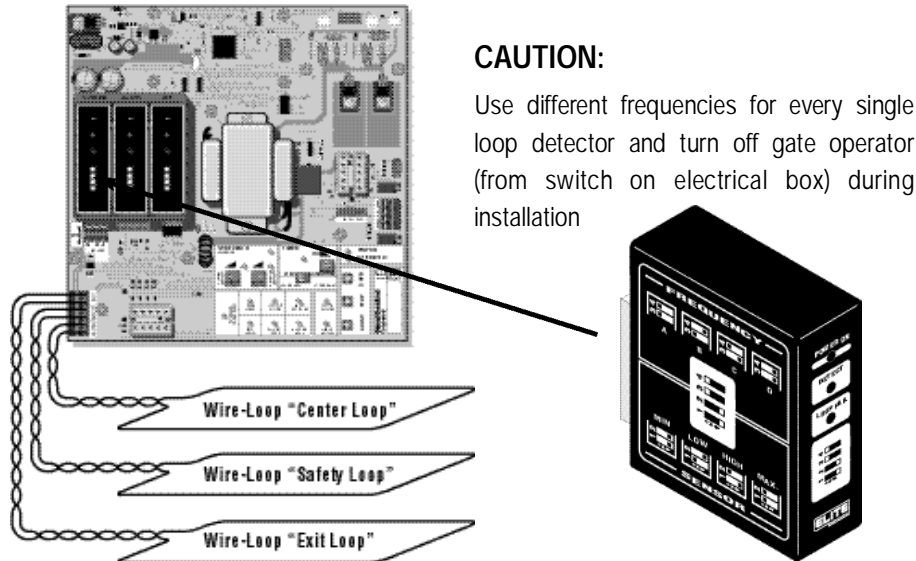

Elite Loop detectors (Model # ELD) needed to do this function.

THREE PUSH BUTTON STATION

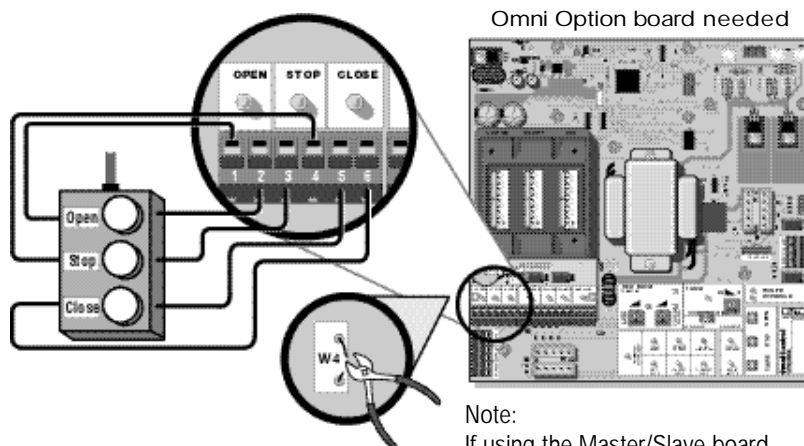

THREE PUSH BUTTON SYSTEM (OPEN-STOP-CLOSE)

- Step 1 - Cut off jumper wire #W4.
- Step 2 - Install optional Omni board.
- Step 3 - Connect **OPEN** push button to #1 & 2.
- Step 4 - Connect **STOP** push button to #3 & 4.
- Step 5 - Connect **CLOSE** push button to #5 & 6.

Note:

If using the Master/Slave board configuration, unplug the Master/Slave link plug on main board and connect it into the optional board M/S link socket.

CAUTION:

Make sure each push button is dry contact and there are no jumper wires between them.

TERMINAL INPUT CONNECTIONS

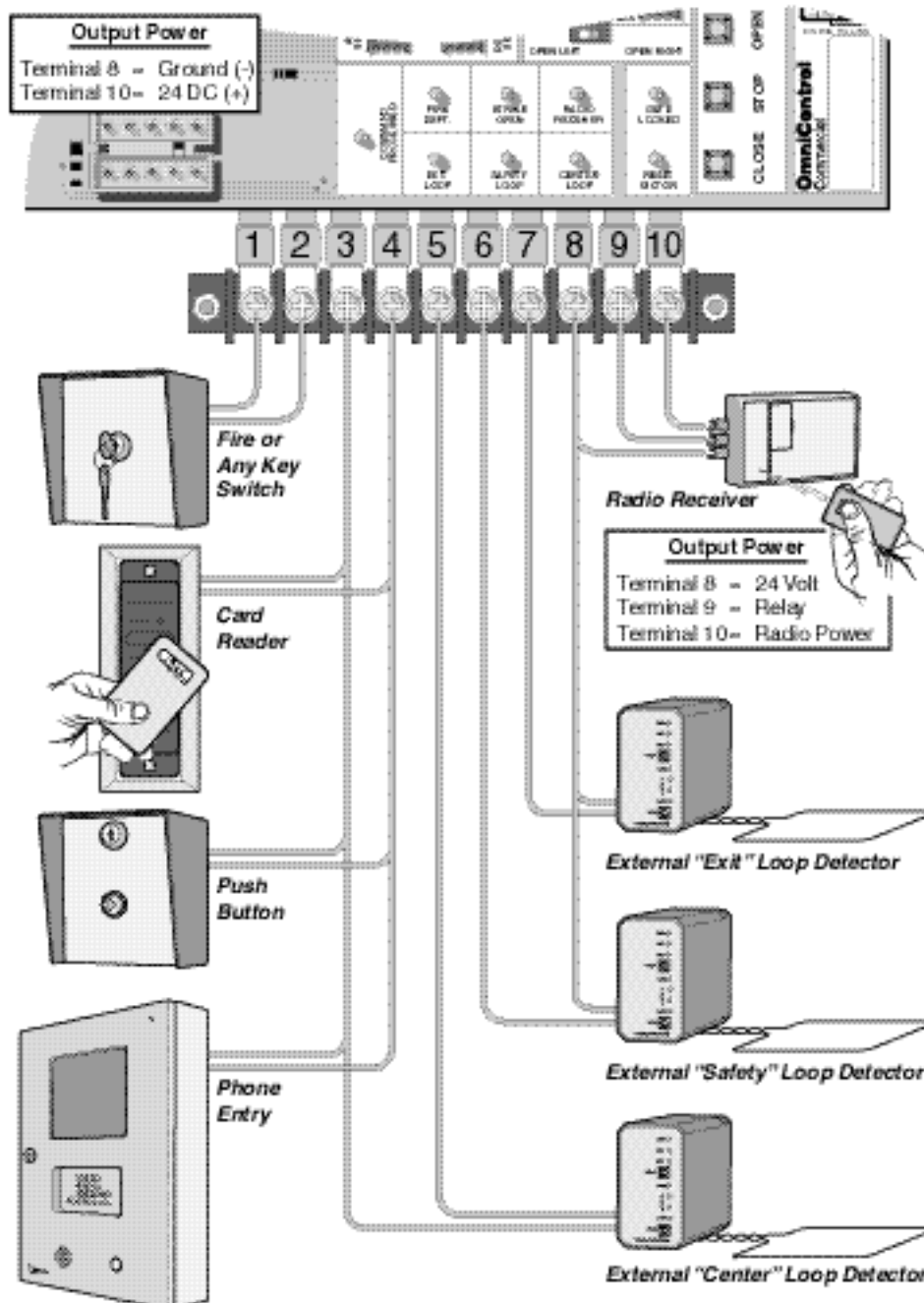

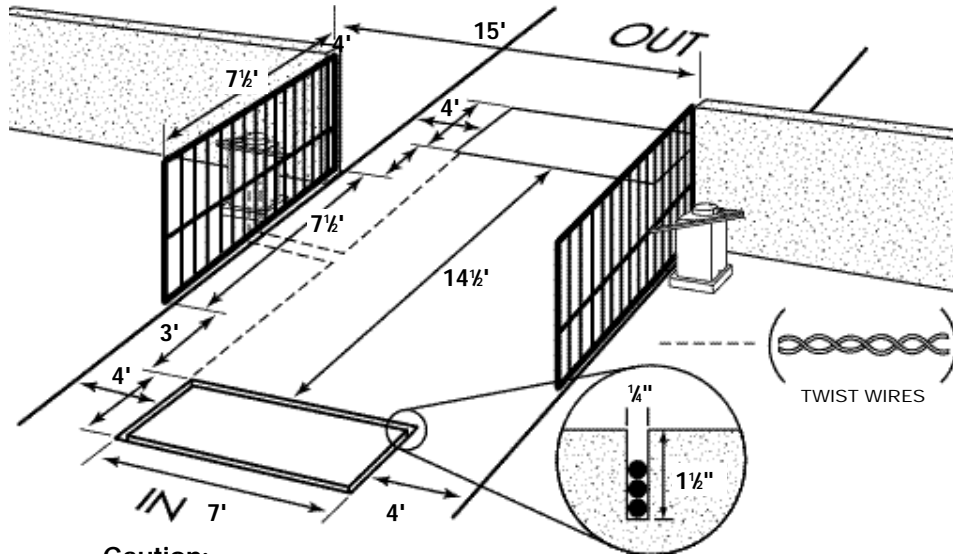

SAFETY LOOP SYSTEM

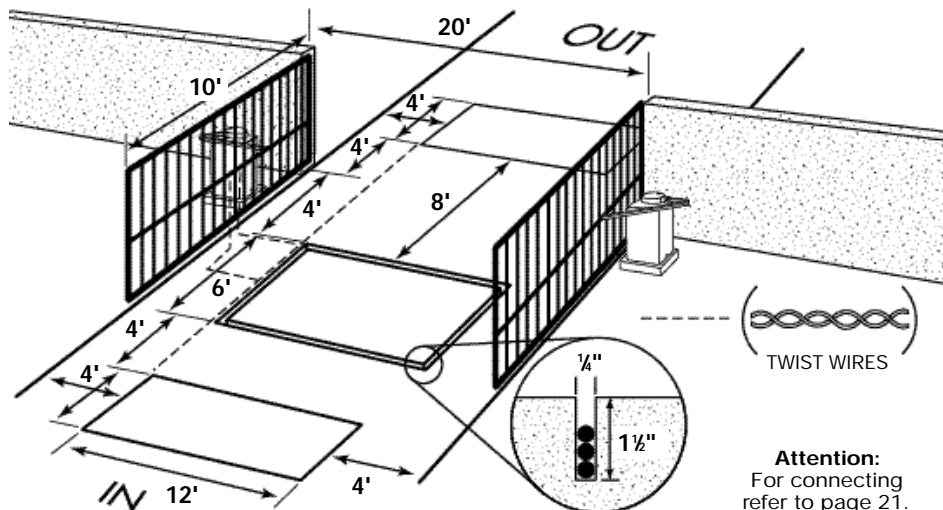

Caution:  Suggested for vehicles 14 feet long or longer. If a vehicle is shorter, a center loop system is recommended and should be installed.

CENTER LOOP SYSTEM



Caution:  This option is for all vehicles including ones less than 14' long. This system requires two loop detectors.

Attention:
For connecting refer to page 21.

EXIT LOOP SYSTEM

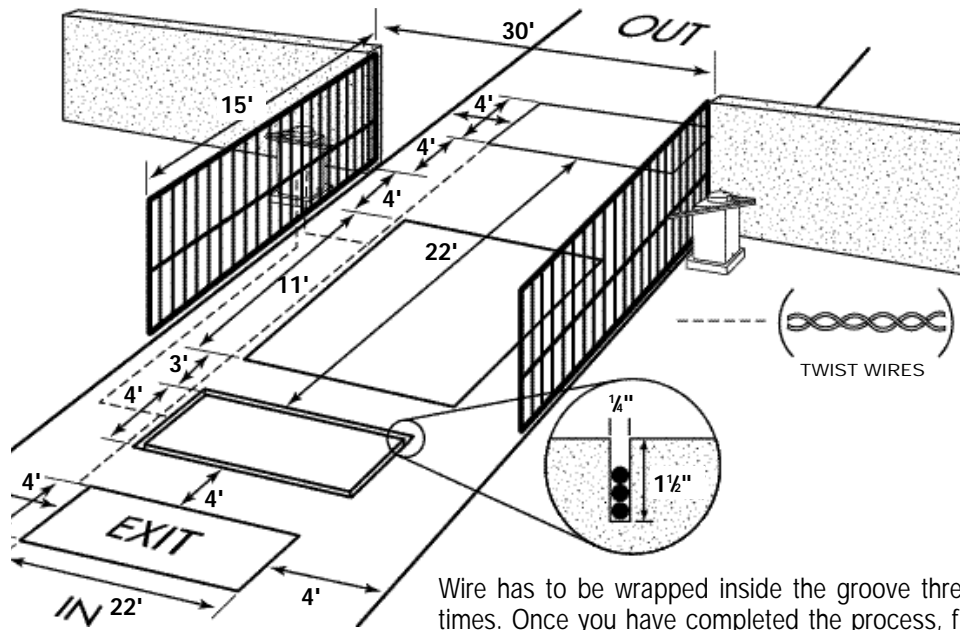

Wire has to be wrapped inside the groove three times. Once you have completed the process, fill up the grooves with a proper sealer.

The reason for an exit loop is so the gate will open automatically when a car is exiting.

ACCESS DOOR

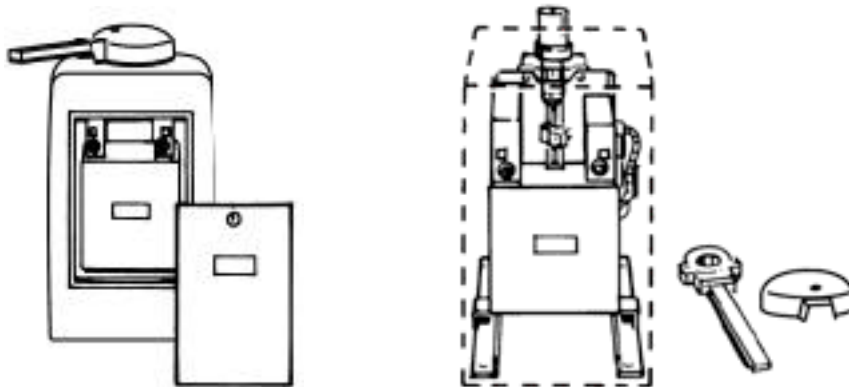

Access Door - Plenty of space is allowed for loop detector and radio receiver. In order to have a stronger attachment, use Velcro on the loop detector.

EMERGENCY RELEASE

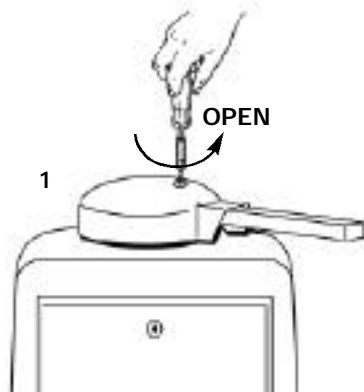

OPTIONAL SAFETY BOLT

Unscrew the bolt and remove the stainless steel cover (special wrench is required).

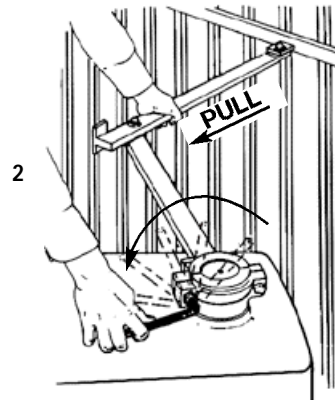

Pull the red handle as shown in the illustration; at this point, the gate is released.

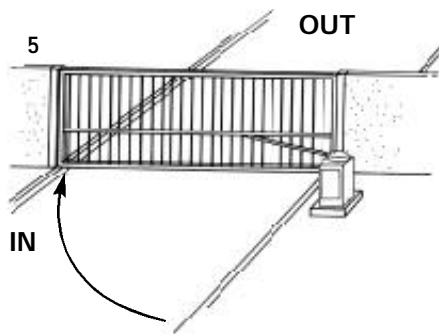
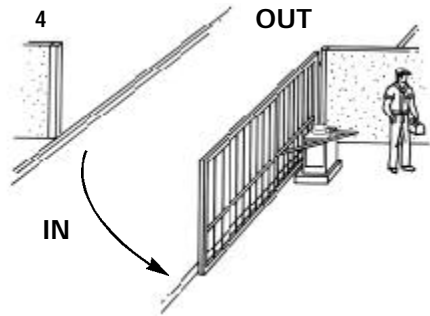
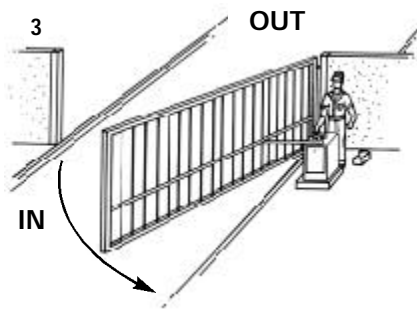

Place the handle and cover in original positions. Once the power is on, the gate will readjust itself automatically.

HOW TO REPLACE THE CONTROL BOARD

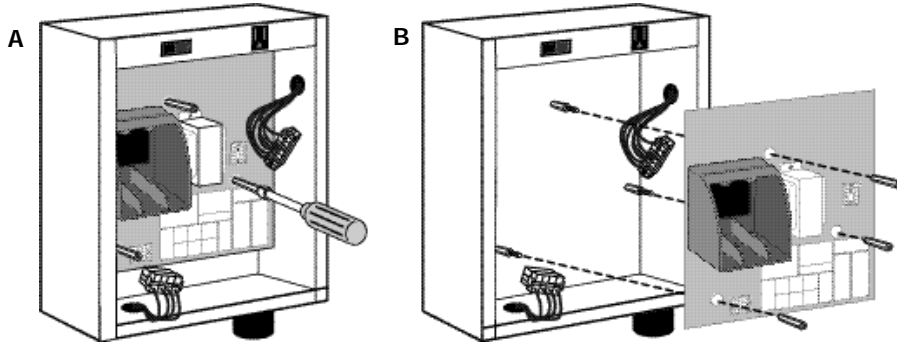

A Disconnect harnesses from board.

B Unscrew 3 nuts and pull out the control board.

AUDIO ALARM

When one of the following events happen **twice consecutively**, an alarm will sound.



1. The gate is too heavy or the arm is installed wrong (Refer to page 9).

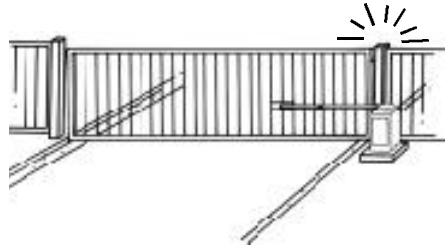
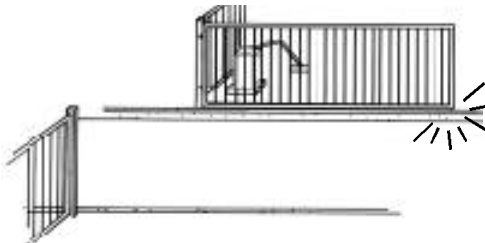

2. The gate hits the driveway, curb or other, and gets stuck in an awkward position.



3. Gate hinges are too tight or broken and the gate is not moving freely

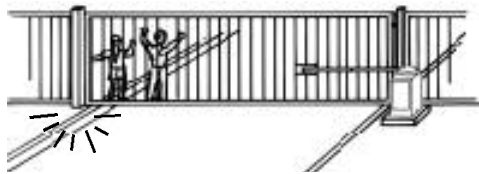

4. An object is on the gate frame while the gate is moving.



5. The gate is moving and an object pushes the gate.

Refer to troubleshooting table.

OPTIONAL DC-1000U BACK UP

POWER BACK-UP

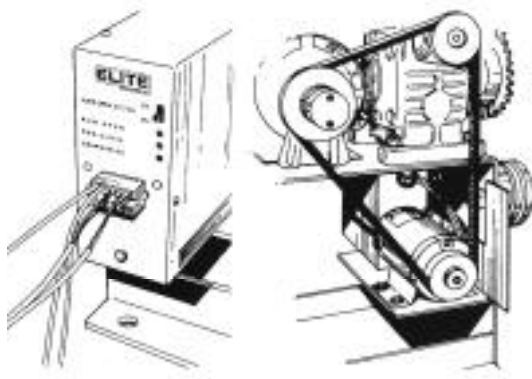

OPTION A:

In case of power failure the gate opens automatically one time and stays open. when power is restored the operator returns to normal condition.

OPTION B:

In case of power failure the gate will not open automatically until activated by a key switch or push button.

**FOR MORE DETAILS
ASK YOUR LOCAL DEALER**

STOP BUTTON ALARM SHUT-OFF

FOR USE WITH OPTIONAL BOARD



This is an important command required to stop the audio alarm in case it has been triggered.

Otherwise the alarm will sound for 5 minutes and reset itself.

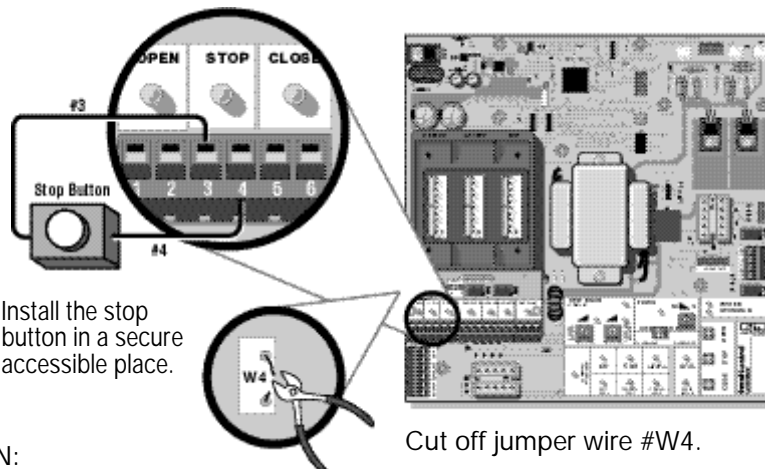

Install the stop button in a secure accessible place.

Cut off jumper wire #W4.

USE THIS BUTTON:

- To stop movement of gate in case of potential entrapment
- To reset the audio alarm (check for obstructions)
- To stop gate operator while traveling

When using the optional board, use the STOP input to connect the stop button.

UPHILL DRIVE WAY INSTALLATION

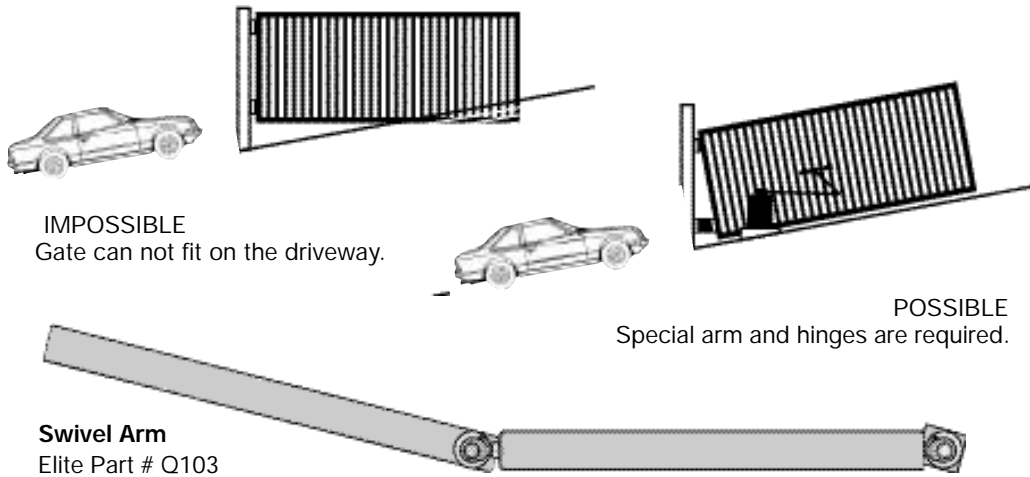

SECONDARY ENTRAPMENT WIRING

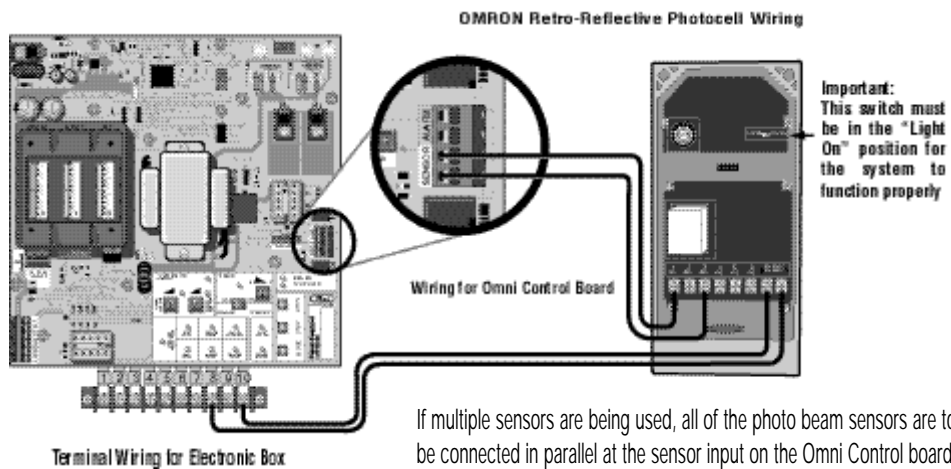

If you are going to use a non-contact sensor as a secondary entrapment protection you should use a recognized component to component to comply with the revised UL 325 intended to be use in class I or class II gate operator, like the following: OMRON Retro-Reflective Photocell, Model: E3K-R10K4-NR

ELITE Model # A OMRON

SECONDARY ENTRAPMENT MOUNTING

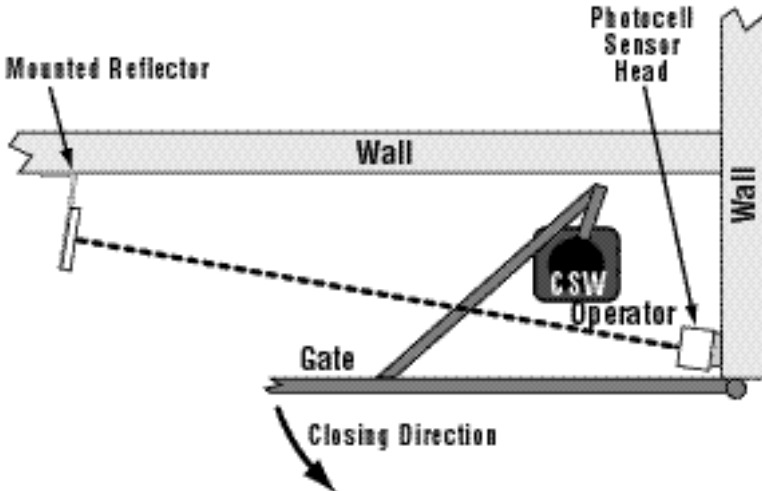
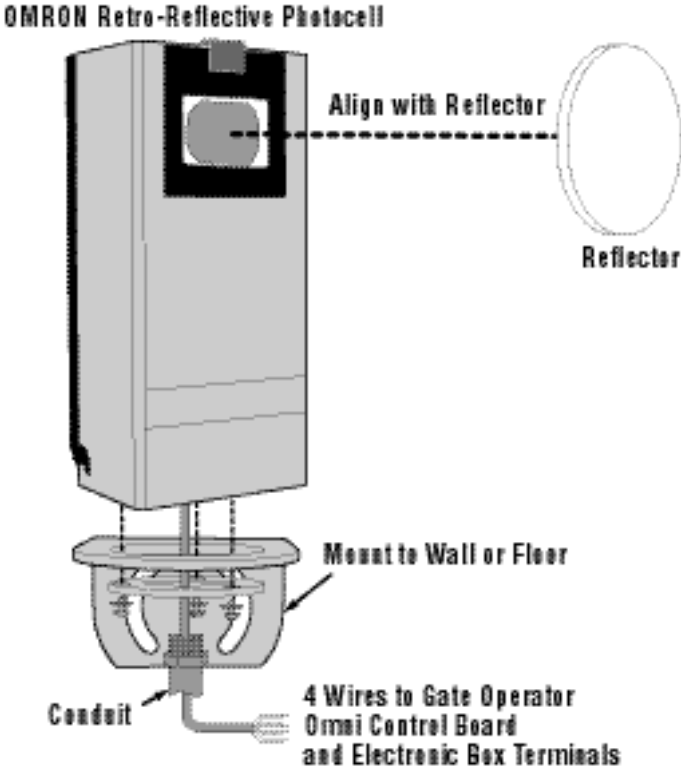

TROUBLESHOOTING LED INFORMATION

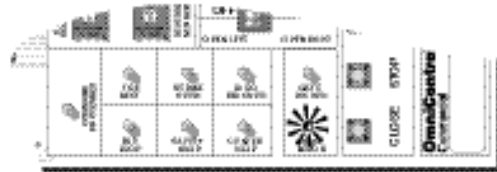
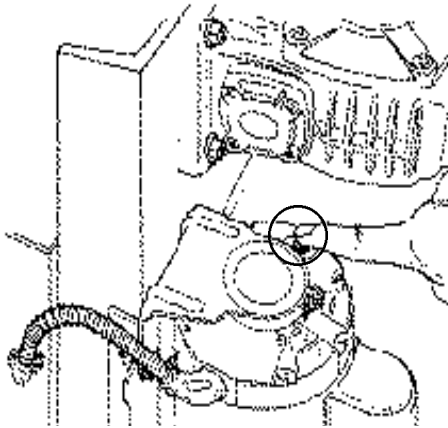

If the gate is not moving in any direction and the reset motor light is on, reset thermal breaker on the motor as directed in the picture.

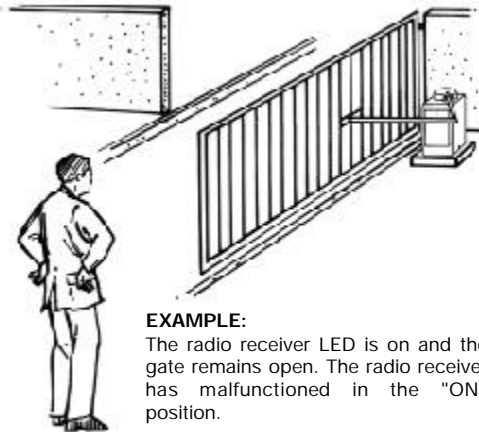

EXAMPLE:
The radio receiver LED is on and the gate remains open. The radio receiver has malfunctioned in the "ON" position.

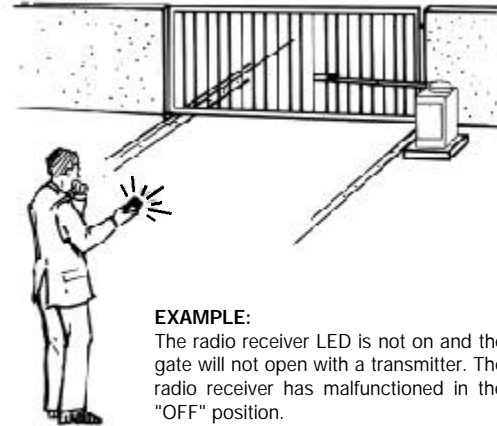

EXAMPLE:
The radio receiver LED is not on and the gate will not open with a transmitter. The radio receiver has malfunctioned in the "OFF" position.

TROUBLESHOOTING TABLE

CONDITION	POSSIBLE CAUSES	SOLUTION
OVERLOAD LED ON And POWER LED OFF	<ol style="list-style-type: none"> 1.Short circuit at terminals 8 and 10 2.Short circuit at any of the loop detectors in the board 3.Short circuit in the control board 	<ol style="list-style-type: none"> 1.Remove the short circuit condition at the terminals 2.Remove the defective loop detector 3.Sent the board to repair
OVERLOAD LED ON And POWER LED ON	<ol style="list-style-type: none"> 1. Excessive current draw at terminal 10 2. Over-voltage at the 120 VAC line input 	<ol style="list-style-type: none"> 1. Reduce the accessories load from terminal 10 2. Verify your electrical power
SYSTEM ON LED FLASHING	<ol style="list-style-type: none"> 1. One limit switch is faulty 2. Motor thermal fuse has pop-out 	<ol style="list-style-type: none"> 1. Test the limit switches and wire connections, fix the fault 2.Reset the motor
REVERSE SENSOR LED ON	<ol style="list-style-type: none"> 1.Gate has encounter and obstruction during traveling 2.Reverse sensor is extra sensitive 	<ol style="list-style-type: none"> 1.Remove the obstruction 2. Turn counter-clock-wise the reverse sensor pot a bit more and try again
ALARM SENSOR LED ON	<ol style="list-style-type: none"> 1.Gate encountered and obstruction during traveling 2.Alarm sensor is extra sensitive 	<ol style="list-style-type: none"> 1.Remove the obstruction 2. Turn counter-clock-wise the alarm sensor pot a bit more and try again
ALARM SENSOR LED ON	<ol style="list-style-type: none"> 1.Gate encountered and obstruction during traveling 2.Alarm sensor is extra sensitive 	<ol style="list-style-type: none"> 1.Remove the obstruction 2. Turn counter-clock-wise the alarm sensor pot a bit more and try again
COMMAND PROCESSED ON	<ol style="list-style-type: none"> 1. There is a command hold active 	<ol style="list-style-type: none"> 1.This is a normal response of the gate operator. It does not represent necessarily that there is a problem.
TIMER LED BLINKING And COMMAND PROCESSED BLINKING	<ol style="list-style-type: none"> 1. There is a command holding the gate open 	<ol style="list-style-type: none"> 1.This is a normal response of the gate operator. It does not represent necessarily that there is a problem. Check inputs for command.
TIMER LED BLINKING And COMMAND PROCESSED BLINKING And REVERSE SENSOR LED ON	<ol style="list-style-type: none"> 1.Gate has reopened because it encountered an obstruction while closing. 	<ol style="list-style-type: none"> 1.Any re-new command will resume normal operation. Check for obstructions. 2. You can stop the alarm by using the stop button.
AUDIO ALARM ON	<ol style="list-style-type: none"> 1.Gate has encountered two consecutive obstructions while trying to close or open 	<ol style="list-style-type: none"> 1.Any re-new command will resume normal operation but not a radio command. Check for obstructions.
ANY "LOOP LED" ON And NO VEHICLE ON THE SENSING AREA	<ol style="list-style-type: none"> 1.The loop detector needs to be reset. 2.The wire loop has been disrupted 3.The loop detector needs to work in a different frequency 4.The loop detector is too sensitive 	<ol style="list-style-type: none"> 1.Reset the loop detector (If you use Elite Plug-in Loop detectors, change the setting for sensitivity and come back to your original setting). 2. Verify and correct connections 3.Set a different working frequency 4.Decrease the sensitivity of the loop detector

CSW-200 PARTS

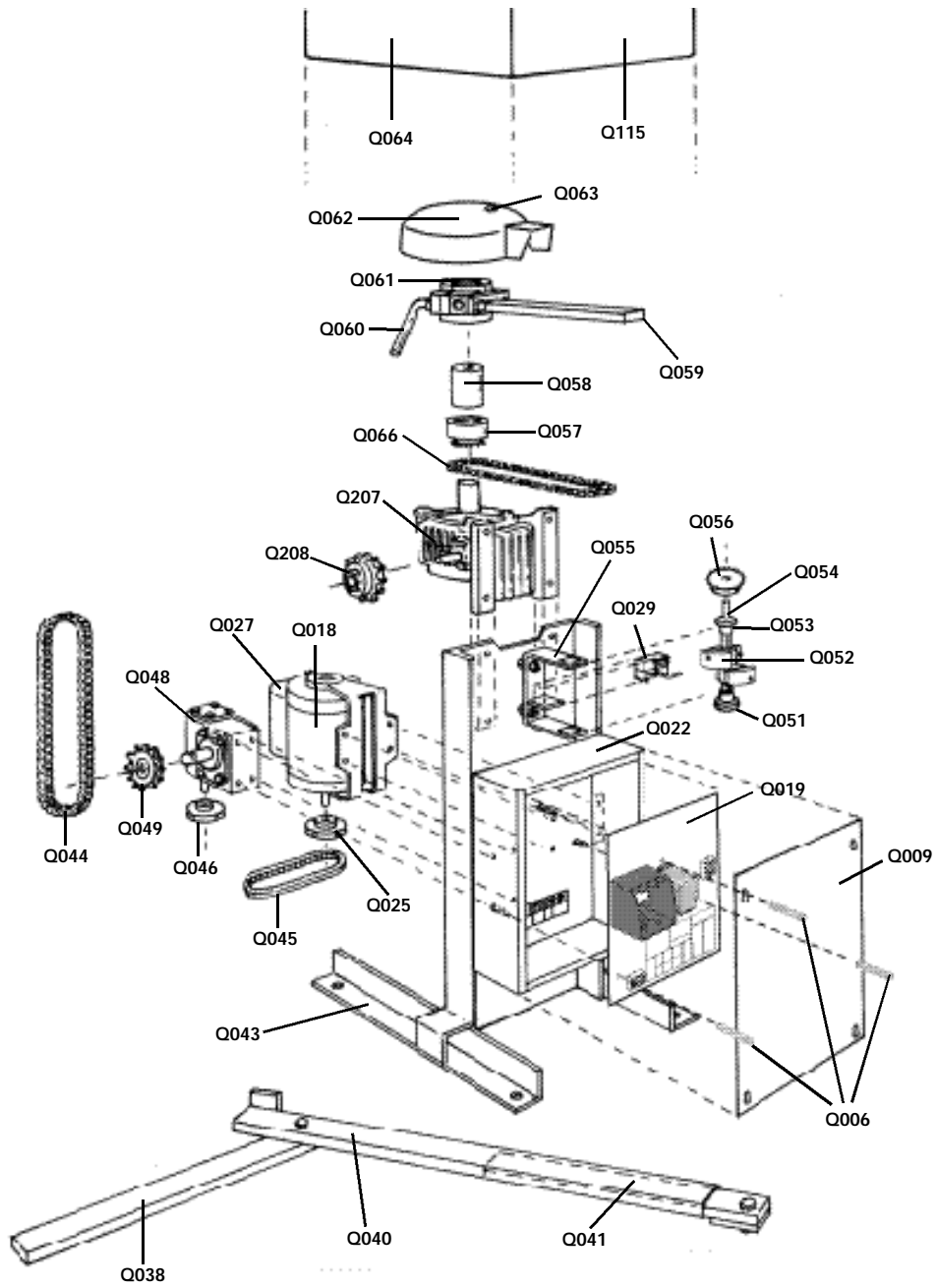

CSW-200 PARTS LIST

Q038 - SHORT ARM	Q025 - MOTOR PULLEY
Q040 - LONG ARM	Q054 - GATE ADJUSTMENT SHAFT
Q041 - ADJUSTABLE SOLID METAL	Q027 - MOTOR CAPACITOR
Q006 - PC BOARD NUTS (SET)	Q055 - LIMIT SWITCH HOLDER
Q043 - CSW-200 CHASSIS	Q029 - LIMIT SWITCH
Q009 - ELECTRONIC ACCESS PANEL	Q056 - SPROCKET GATE ADJUSTMENT
Q044 - CHAIN #50	Q057 - OUTPUT SHAFT SPROCKET
Q045 - DRIVE BELT	Q058 - 21/2" OUTPUT SHAFT
Q046 - GEAR REDUCER PULLEY	Q059 - OUTPUT ARM SOLID
Q208 - CLUTCH	Q060 - ARM RELEASE
Q048 - GEAR REDUCER (GEAR BOX, SIZE 40)	Q061 - OUTPUT SHAFT CLUTCH
Q049 - SPROCKET (B50-16)	Q062 - ARM COVER
Q207 - GEAR REDUCER (GEAR BOX, SIZE 60)*	Q063 - SECURITY BOLT
Q019 - ELECTRONIC CONTROL BOARD	Q064 - OPERATOR COVER - NON UL **
Q018 - 1/2 HP ELECTRIC MOTOR	Q115 - OPERATOR COVER - UL **
Q051 - COLLAR	Q066 - CHAIN #25
Q052 - GATE ADJUSTMENT (PLASTIC PART)	*OPERATOR SERIAL NUMBER REQUIRED WHEN ORDERING
Q022 - ELECTRONIC BOX	**ACCESS DOOR OPTIONAL
Q053 - BALL BEARING	

MAINTENANCE

1. THE GATE AREA SHOULD BE KEPT CLEAN TO INSURE PROPER OPERATION.
2. MAKE SURE HINGES ARE WORKING SMOOTHLY AND LUBRICATED PROPERLY.
3. KEEP THE COVER CLEAN.
4. FOR PARTS, REFER TO PAGE 31.

IF YOU NEED FURTHER ASSISTANCE, PLEASE CALL YOUR LOCAL SERVICE COMPANY.

AVAILABLE PRODUCTS

